

This publication, including all photographs, illustrations and software, is protected under international copyright laws, with all rights reserved. Neither this manual, nor any of the material contained herein, may be reproduced without the express written consent of the manufacturer.

The information in this document is subject to change without notice. The manufacturer makes no representations or warranties with respect to the contents hereof and specifically disclaims any implied warranties of merchantability or fitness for any particular purpose. Further, the manufacturer reserves the right to revise this publication and to make changes from time to time in the content hereof without obligation of the manufacturer to notify any person of such revision or changes.

Trademarks

IBM, VGA, OS/2, and PS/2 are registered trademarks of International Business Machines.

Intel, Pentium, Pentium-II, MMX, and Celeron are registered trademarks of Intel Corporation.

Microsoft, MS-DOS and Windows 95/98/NT are registered trademarks of Microsoft Corporation.

Sound Blaster and SB-Link are trademarks of Creative Technology Ltd.

PC-cillin and ChipAway Virus are trademarks of Trend Micro Inc.

AMI is a trademark of American Megatrends Inc.

A3D is a registered trademark of Aureal Inc.

Other names used in this publication may be trademarks and are acknowledged.

**Copyright © 1999
All Rights Reserved
M748LMRT, Version 1.3
S6T/April 1999**

Federal Communications Commission (FCC)

This equipment has been tested and found to comply with the limits for a Class B digital device, pursuant to Part 15 of the FCC Rules. These limits are designed to provide reasonable protection against harmful interference in a residential installation. This equipment generates, uses, and can radiate radio frequency energy and, if not installed and used in accordance with the instructions, may cause harmful interference to radio communications. However there is no guarantee that interference will not occur in a particular installation. If this equipment does cause harmful interference to radio or television reception, which can be determined by turning the equipment off and on, the user is encouraged to try to correct the interference by one or more of the following measures:

- Reorient or relocate the receiving antenna.
- Increase the separation between the equipment and the receiver.
- Connect the equipment onto an outlet on a circuit different from that to which the receiver is connected.
- Consult the dealer or an experienced radio/TV technician for help.

Shielded interconnect cables and shielded AC power cable must be employed with this equipment to insure compliance with the pertinent RF emission limits governing this device. Changes or modifications not expressly approved by the system's manufacturer could void the user's authority to operate the equipment.

Declaration of Conformity

This device complies with part 15 of the FCC rules. Operation is subject to the following conditions:

- This device may not cause harmful interference, and
- This device must accept any interference received, including interference that may cause undesired operation.

Canadian Department of Communications

This class B digital apparatus meets all requirements of the Canadian Interference-causing Equipment Regulations.

Cet appareil numérique de la classe B respecte toutes les exigences du Règlement sur le matériel brouilleur du Canada.

Table of Contents

Chapter 1 Introduction.....	1
Key Features.....	2
Slot-1 Processor Support.....	2
Socket-370 Processor Support.....	2
Memory Support.....	2
Expansion Slots.....	2
Onboard IDE channels.....	2
Power Supply and Power Management.....	2
Built-in Graphics System.....	3
Sound System.....	3
Onboard I/O Ports.....	3
Hardware Monitoring.....	4
Built-in LAN Adapter.....	4
Fax/modem DAA Module.....	4
Onboard Flash ROM.....	4
Bundled Software.....	4
Dimensions.....	5
Package Contents.....	5
Optional Accessories.....	5
Static Electricity Precautions.....	6
Chapter 2 Mainboard Installation.....	7
Mainboard Components.....	8
Install the Processor.....	9
Installing a Slot-1 Processor Cartridge.....	10
Installing a Socket-370 Processor.....	11
Install Memory.....	12
Set the Jumpers.....	13
Jumper JP1: Keyboard Power On Selector.....	14
Jumper JP5: Clear CMOS Memory.....	14
Jumper JP4: Enable/Disable Onboard Audio.....	14
Jumper JP3: Enable/Disable Onboard LAN.....	15
Jumper JP9: Enable/Disable Onboard Fax/modem.....	15
Jumper JP7: Select Slot-1 or Socket-370 Processor.....	15
Install the Mainboard.....	16
Install the Extension Brackets.....	18
Audio Ports and Game/MIDI Port Extension Bracket.....	18
Serial/Parallel Ports Extension Bracket.....	19
LAN Adapter Extension Bracket.....	20
Fax/modem DAA Module.....	20
VGA Extension Card.....	21

Optional Extension Brackets	22
ATX Form Card.....	22
Digital Audio Extension Bracket.....	23
Install Other Devices	24
Floppy Disk Drive	24
IDE Devices	24
Internal Sound Connections.....	25
Digital Audio Connection	25
Expansion Slots	26
LAN Wake Up.....	26
Chapter 3 BIOS Setup.....	27
Introduction	27
Running the Setup Utility	28
Standard CMOS Setup Page.....	29
Advanced Setup Page.....	30
Power Management Setup Page.....	32
PCI / Plug and Play Setup Page	33
Load Optimal Settings.....	34
Load Best Performance Settings	34
Features Setup Page	35
CPU PnP Setup Page.....	36
Hardware Monitor Page	37
Change Password.....	38
Change or Remove the Password.....	38
Exit.....	38
Chapter 4 Software & Applications.....	39
Introduction	39
Bus Master IDE Driver	39
USB Driver.....	39
Sound Driver	40
Graphics Drivers and Software.....	40
Fax/Modem Drivers and Software	40
Network Adapter Driver.....	40
BIOS Update Utility	40
PC-Cillin Software.....	40
ADCM Software.....	41
Using the PCI Sound Application	41
The Four Speakers System	42
Speaker Installation.....	42
Speaker Position	42
Mixer Setup	42
Demo.....	43

Chapter 1

Introduction

This mainboard has a **slot-1** processor socket for an **Intel processor cartridge**, and it also has a **socket-370** for an **Intel PPGA (Plastic Pin Grid Array) Celeron** processor. You can install either one of these processors according to the power and performance requirements that you need from your system. *Note that you cannot install two processors on this mainboard.*

Slot-1 processors include the **SEPP (Single Edge Processor Package) Celeron, the Pentium-II, and the Pentium-III**. Clock rates run as high as **550 MHz**. Socket-370 processors are the **PPGA Celeron** which runs at clock rates up to **466 MHz**. The mainboard supports a system bus of **66 MHz** or **100 MHz**.

The mainboard uses the Xcel 2000 chipset which provides **CPU Plug & Play** through firmware. The mainboard is highly integrated and includes a built-in **64-bit AGP Graphics Accelerator**, a built-in **PCI 3D Sound System**, and a built-in **10BaseT/100BaseTX Network Adapter**. A **V.90 Fax/modem DAA module** is also shipped with the mainboard. In addition, it has a full set of **ATX I/O Ports** including a serial port, one PS/2 ports, a parallel port and two USB ports.

This mainboard has all the features you need to develop a powerful multimedia workstation that is network ready, and has built-in communications. The board is **baby-AT sized** and has power connectors for **ATX** and **AT** power supply units and it can be installed in AT system case.

Key Features

This key features of this mainboard include:

Slot-1 Processor Support

- ◆ **Pentium-III** support for 450 MHz and 550 MHz clock rates
- ◆ **Pentium-II** support for 233 MHz to 450 MHz clock rates
- ◆ **SEPP Celeron** support for 266 MHz to 433 MHz clock rates
- ◆ Support for 66 MHz and 100 MHz FSB (Front Side Bus)
- ◆ All processors configured by **CPU Plug & Play**

Socket-370 Processor Support

- ◆ The **PPGA Celeron** provides Pentium-II performance with integrated level 1 and level 2 cache memory
- ◆ PPGA Celerons run from 300 MHz through to 466 MHz.
- ◆ Supports a 66 MHz front side system bus
- ◆ All Celerons are automatically configured using firmware

Memory Support

- ◆ Three DIMM slots for SDRAM 168-pin memory modules
- ◆ Support for 66 MHz & 100 MHz memory bus
- ◆ Maximum installed memory can be 3 x 256 MB = 768 MB

Expansion Slots

- ◆ One 32-bit PCI slot
- ◆ One 8/16-bit ISA slot

Onboard IDE channels

- ◆ Primary and Secondary PCI IDE channels
- ◆ Support for PIO (programmable input/output) modes
- ◆ Support for Bus mastering and UltraDMA 33/66 modes

Power Supply and Power Management

- ◆ Dual connector for either an AT or ATX power supply

- ◆ Support for Green PC standard, suspend switch, keyboard power on/off
- ◆ Supports Wake on Modem, Wake on LAN and Wake on Alarm

Built-in Graphics System

- ◆ Onboard 64-bit 3D **AGP Graphics Accelerator**
- ◆ Complies with AGP Ver.1 with 66/133 MHz operation
- ◆ Shared memory architecture allows a maximum of 8 MB main memory to act as frame buffer
- ◆ Supports high resolutions up to 1600 x 1200 pixels

Sound System

- ◆ Meets PC98 audio specification
- ◆ Full duplex playback and recording with built-in 16-bit CODEC
- ◆ HRTF 3D professional audio supports both Direct Sound 3D® and A3D® compatible interface plus support for **4-channel speakers**
- ◆ Drivers support DOS/Windows 95/98/2000/NT 4.0
- ◆ Built-in 32 ohm earphone buffer and 3D surround
- ◆ Provides MPU-401 Game/MIDI port and legacy Sound Blaster 16 support
- ◆ Downloadable Wave-table Synthesizer supports Direct Music®
- ◆ Digital Audio Interface (SPDIF In/Out) with **24-bit stereo**, 44KHz sampling rate and measured **120dB** audio quality
- ◆ Stereo Mixer supports analog mixing from CD-Audio, Line-In, and digital mixing from voice, FM/Wave-table and digital CD-Audio

Onboard I/O Ports

- ◆ Floppy disk drive port with 1Mb/s transfer rate
- ◆ One serial ports with 16550-compatible fast UART
- ◆ One parallel port with support for ECP and EPP
- ◆ Two USB ports
- ◆ One PS/2 port (for mouse)
- ◆ One infrared port

Hardware Monitoring

- ◆ Built-in hardware monitoring for CPU temperature and fan speeds
- ◆ Supports AMI's Desktop Client Manager (ADCM)

Built-in LAN Adapter

- ◆ Onboard **10BaseT/100BaseTX LAN Adapter**
- ◆ LAN controller integrates Fast Ethernet MAC and PHY compliant with IEEE802.3u 100BASE-TX, 10BASE-T and ANSI X3T12 TP-PMD standards
- ◆ Compliant with ACPI 1.0 and the Network Device Class Power Management 1.0
- ◆ High Performance provided by 100 Mbps clock generator and data recovery circuit for 100 Mbps receiver

Fax/modem DAA Module

- ◆ **56 Kbps Fax/modem DAA module**
- ◆ Supports V.90, V.34, V.32bis, V.32, V.22bis, V.22
- ◆ Supports Auto Fallback, Caller ID and MNP 5, V.42bis data compression with 115200 compatible Virtual UART
- ◆ Requires 16 MB RAM and WIN 95/98/NT

Onboard Flash ROM

- ◆ Provides plug and play function for automatic CPU and board configuration
- ◆ Supports plug and play configuration of peripheral devices and expansion cards
- ◆ Built-in virus protection using **Trend's ChipAway Virus** which ensures that the entire boot process is virus protected.

Bundled Software

- ◆ **AMI Desktop Client Manager** supports hardware monitoring on stand alone systems or over a network
- ◆ **PC-Cillin** provides automatic virus protection under Windows 95/98
- ◆ **SuperVoice** fax/modem and voice software

- ◆ **Media Ring Talk** provides PC to PC base internet phone communication
- ◆ **Gamut 98** provides professional audio applications included MP3 playback

Dimensions

- ◆ Baby-AT form factor (22cm x 22cm)

Package Contents

Your mainboard package ships with the following items:

- Mainboard
- This User's guide
- IDE cable
- Floppy diskette drive cable
- Audio ports and Game/MIDI port extension bracket
- Serial/Parallel ports extension bracket
- VGA extension bracket
- Fax/modem DAA module
- Network adapter extension bracket
- Support software CD-ROM

Optional Accessories

You can purchase the following optional accessories for this mainboard.

- ATX Form Card (2 USB ports, IR port & PS/2 port)
- Digital Audio extension bracket

Static Electricity Precautions

1. Components on this mainboard can be damaged by static electricity. Take the following precautions when unpacking the mainboard and installing it in a system.
2. Keep the mainboard, and other components, in their original static-proof packaging until you are ready to install them.
3. During an installation, wear a grounded wrist strap if possible. If you don't have a wrist strap, frequently discharge any static electricity by touching the bare metal of the system chassis.
4. Handle the mainboard carefully by the edges. Avoid touching the components unless it is absolutely necessary. During the installation lay the mainboard on top of the static-proof packaging with the component side facing upwards.
5. Inspect the mainboard for any damage caused during transit. Ensure that all the components that are plugged into sockets are correctly seated.
6. If you suspect that the mainboard has been damaged, do not apply power to the system. Contact your mainboard vendor and report the damage.

Chapter 2

Mainboard Installation

To install this mainboard into your system, follow the procedures in this chapter:

- ❑ Identify the mainboard components
- ❑ Install the correct processor
- ❑ Install one or more memory modules
- ❑ Verify that any jumpers or switches are at the correct setting
- ❑ Install the mainboard in the system chassis
- ❑ Install any extension cables to the mainboard headers
- ❑ Install any other devices and make the appropriate connections to the mainboard headers.

Note: 1. Before installing the mainboard, you must ensure that the Clear CMOS jumper JP5 is set to the Normal setting. See this chapter for information locating JP5 and changing the jumper setting.

2. While installing the mainboard into AT case with ATX power, please make sure the AC power cord is unplugged before the full system is installed completely. Otherwise, it may destroy stuffs unpredictably, due to the power-on trigger event of power management.

Mainboard Components

Use the diagram below to identify the major components on your mainboard.

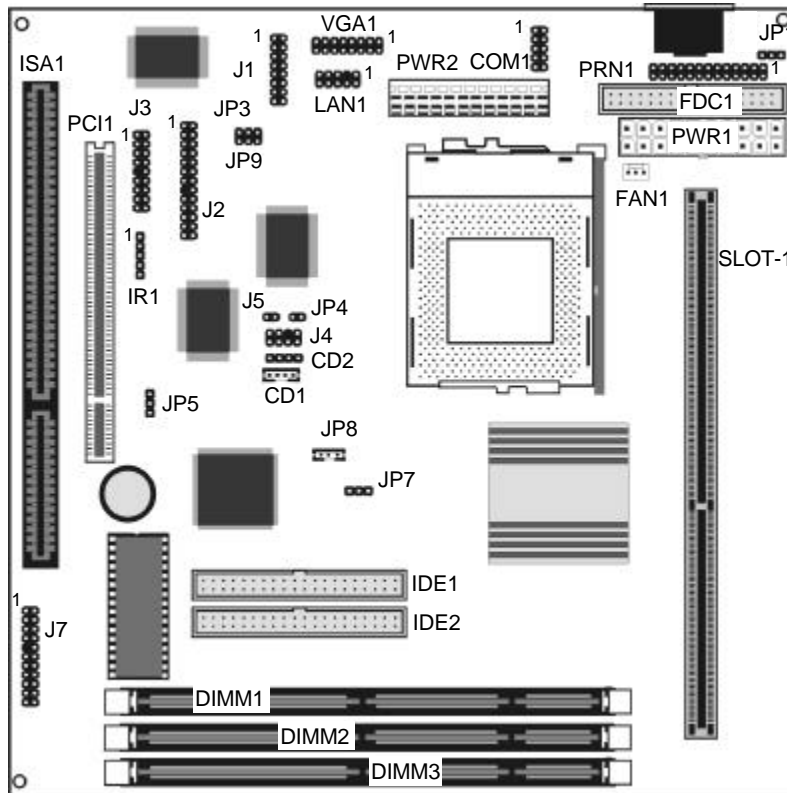

Install the Processor

This mainboard has a Slot-1 which can be installed with any Slot-1 processor cartridge including the Pentium-III, the Pentium-II, and the SEPP Celeron. It also has a Socket-370 which can be installed with the new Celeron processor which is shipped in a PPGA (Plastic Pin Grid Array) package. **To ensure reliability, make sure that your PPGA Celeron processor is fitted with a heatsink/cooling fan assembly.**

You can install a Slot-1 processor or a PPGA Celeron. You cannot install a PPGA and a Slot-1 processor cartridge together. Take care that you do not try to install a Socket-7 processor into the Socket-370. A Socket-7 processor such as the Pentium-MMX, or the AMD K5/K6 does not fit in the socket-370. The following table lists the processors that are currently supported by this mainboard. New processors may be released after this manual is printed.

Processor Cartridge	Clock Rate MHz	Processor Socket	System Bus MHz
Pentium-III	550	Slot-1	100
Pentium-III	500	Slot-1	100
Pentium-III	450	Slot-1	100
Pentium-II	450	Slot-1	100
Pentium-II	400	Slot-1	100
Pentium-II	350	Slot-1	100
Pentium-II	333	Slot-1	66
Pentium-II	300	Slot-1	66
Pentium-II	266	Slot-1	66
Pentium-II	233	Slot-1	66
SEPP Celeron	433	Slot-1	66
SEPP Celeron	400	Slot-1	66
SEPP Celeron	366	Slot-1	66
SEPP Celeron	333	Slot-1	66
SEPP Celeron	300A	Slot-1	66
SEPP Celeron	300	Slot-1	66
SEPP Celeron	266	Slot-1	66
PPGA Celeron	466	Socket-370	66
PPGA Celeron	433	Socket-370	66
PPGA Celeron	400	Socket-370	66
PPGA Celeron	366	Socket-370	66
PPGA Celeron	333	Socket-370	66
PPGA Celeron	300	Socket-370	66

Installing a Slot-1 Processor Cartridge

1. Locate Slot-1, FAN1, and JP7 on the mainboard.

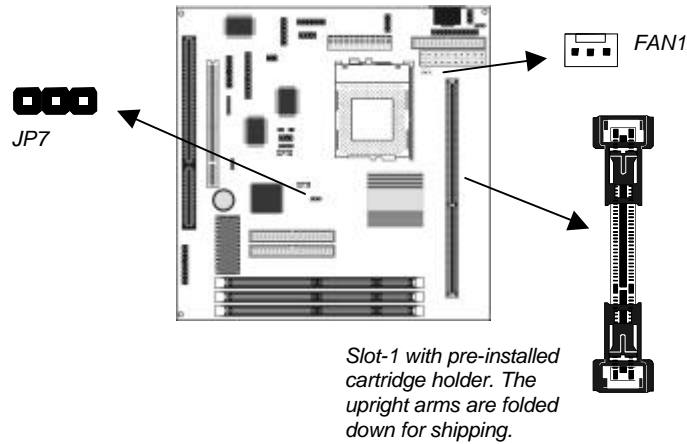

2. The Slot-1 is installed with a cartridge holder. The upright struts of the cartridge holder are folded down for shipping. Pull the struts upwards so that they are in the upright position.

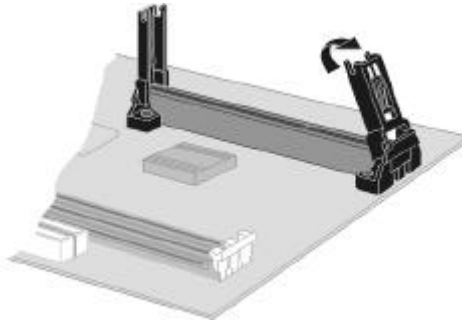

3. Insert the processor cartridge into the cartridge holder. Follow the instructions given with your processor cartridge. The edge connector on the cartridge has a notch so that it only fits into the Slot-1 in the correct way.

4. Locate the cooling fan power supply FAN1. Connect the cable from the processor cartridge cooling fan to FAN1.
5. Locate the jumper JP7. Use this jumper to select if you have installed a Slot-1 processor or a Socket-370 processor. The jumper settings are illustrated below.

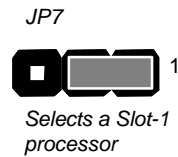
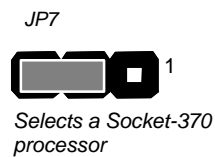

6. On this mainboard, you can configure the processor by entering the correct settings in the BIOS setup utility.

Installing a Socket-370 Processor

The Celeron processor installs into the ZIF (Zero Insertion Force) Socket-370 on the mainboard.

1. Locate the Socket-370, FAN1, and JP7. Pull the locking lever out from the socket and swing it to the upright position.

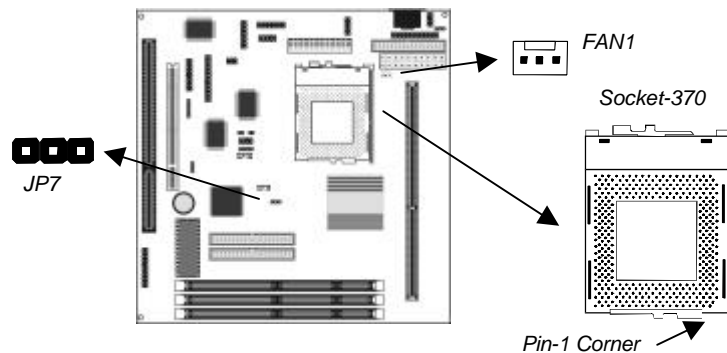

2. On the Celeron processor, identify the pin-1 corner by noting that it has a slight bevel.
3. On the Socket-370, identify the pin-1 corner. The pin-1 corner is on the same side as the locking lever, closest to the top of the lever when it is in the locked position.

- Match the pin-1 corners and insert the Celeron processor into the socket. No force is required and the processor should drop into place freely.
- Swing the locking lever down and hook it under the catch on the side of the socket. This locks the Celeron processor in the socket.
- Locate the jumper JP7. Use this jumper to select if you have installed a Slot-1 processor or a Socket-370 processor. The jumper settings are illustrated below.

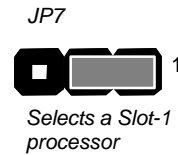
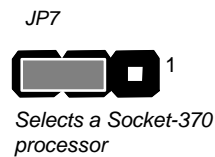

- If the Celeron processor is installed with a cooling fan assembly, connect the cable from the fan to the CPU fan power connector FAN1.

Install Memory

The mainboard has three DIMM slots which can be installed with memory modules. You must install at least one memory module in order to use the mainboard. One memory module must be installed in DIMM1 to provide shared memory for the onboard graphics system.

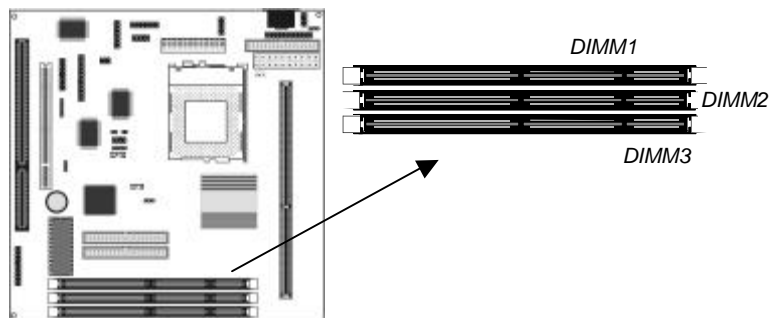

For this mainboard, you must use 168-pin, 3.3V memory modules installed with SDRAM memory chips. If you are using a processor cartridge that runs on a 100 MHz system bus, you must use memory that operates on a 100 MHz memory bus (PC-100 memory). If you are using a processor cartridge that runs on a 66 MHz system bus, you can use memory that operates on a 66 MHz memory bus. You can install any size of memory module from 16 MB up to 256 MB, so the maximum memory size is 3 x 256 MB = 768 MB.

The edge connectors on the memory modules have cut outs, which coincide with struts in the DIMM slots, so the memory modules can only be installed in the correct way.

On the DIMM slot, pull the locking latches at either end of the slots outwards. Position the memory module correctly and insert it into the DIMM slot. Press the module down into the slot so that the locking latches lever inwards and lock the module in place.

Set the Jumpers

Jumpers are sets of pins that can be connected together with jumper caps. The jumper caps change the way the mainboard operates by changing the electronic circuits on the mainboard. If a jumper cap connects two pins, we say the pins are SHORT. If a jumper cap is removed from two pins, the pins are OPEN.

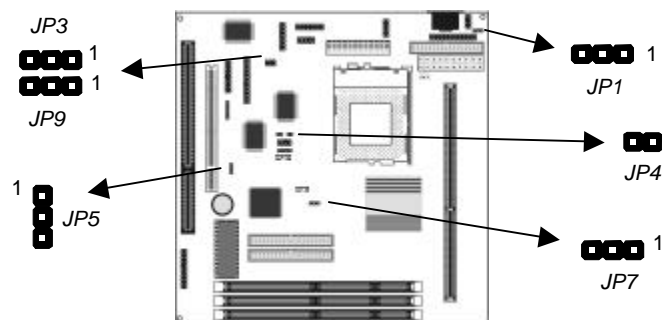

Jumper JP1: Keyboard Power On Selector

If you are using an ATX power supply unit, you can use hot keys on your keyboard as a power on/off switch for the system. Use this jumper to turn this feature on or off.

Note: Make sure that the system can provide 1A on +5VSB (+5V Standby) signal before using the Keyboard Power On function.

Function	Jumper Setting
Disable Keyboard Power On	Short Pins 1-2
Enable Keyboard Power On	Short Pins 2-3

Jumper JP5: Clear CMOS Memory

Use this jumper to clear the contents of the CMOS memory. You may need to clear the CMOS memory if the settings in the setup utility are incorrect and prevent your mainboard from operating. To clear the CMOS memory, disconnect all the power cables from the mainboard and then move the jumper cap into the CLEAR setting for a few seconds.

Function	Jumper Setting
Normal Operation	Short Pins 1-2
Clear CMOS Memory	Short Pins 2-3

Jumper JP4: Enable/Disable Onboard Audio

Use this 2-pin jumper to enable or disable the onboard audio system. If you install a different audio system on an expansion card, you must disable the onboard audio system. If you use this jumper to disable the audio system, it automatically disables the onboard fax/modem, even if the fax/modem jumper JP9 is enabled.

Function	Jumper Setting
Enable Audio	Open Pins 1-2
Disable Audio/Modem	Short Pins 1-2

Jumper JP3: Enable/Disable Onboard LAN

Use this 3-pin jumper to enable or disable the onboard network adapter.

Function	Jumper Setting
Enable Onboard LAN	Short Pins 1-2
Disable Onboard LAN	Short Pins 2-3

Jumper JP9: Enable/Disable Onboard Fax/modem

Use this 3-pin jumper to enable or disable the onboard fax/modem card. If the audio jumper JP4 is disabled, the fax/modem is also disabled, no matter the setting of JP9.

Function	Jumper Setting
Disable Onboard Modem	Short Pins 1-2
Enable Onboard Modem	Short Pins 2-3

JP7: Select Slot-1 or Socket-370 Processor

Use this 3-pin jumper to prepare the mainboard to use either a Slot-1 processor or a Socket-370 processor.

Function	Jumper Setting
Slot-1 Processor	Short Pins 1-2
Socket-370 Processor	Short Pins 2-3

Install the Mainboard

Install the mainboard into the system chassis. This mainboard is baby AT-sized and the I/O ports are provided on extension brackets. In addition the mainboard can operate using an AT power supply unit or an ATX power supply unit. This means that you have a wide choice of cases that can be used by this mainboard.

Install the mainboard into the unit case. Follow the instructions provided by the case manufacturer using the screws and mounting points provided in the chassis.

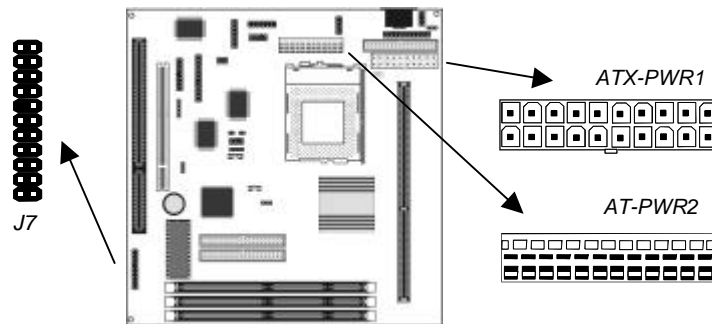

Connect the power cable from the power supply unit to the power connector on the mainboard. If you are using an AT power unit, connect it to the AT power connector PWR2. If you are using an ATX power unit connect it to the ATX power connector PWR1.

Connect the case switches and indicator LEDs to the bank of switch and LED connectors J7. See the illustration below for a guide to the pin functions of the J7 case connector.

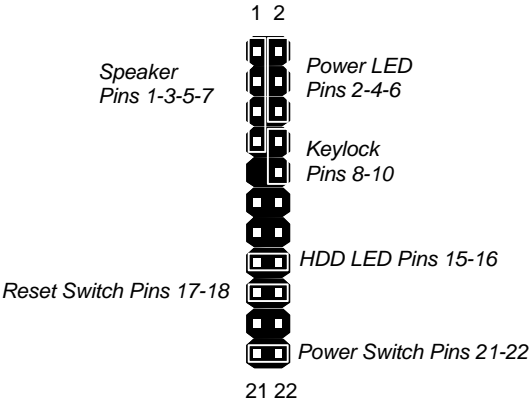

Install the Extension Brackets

The extension brackets are used to transmit features on the mainboard to external connectors that can be fixed to the system chassis. Follow the steps below to install the extension brackets.

***Note:** All the ribbon cables used on the extension brackets carry a red stripe on the pin-1 side of the cable.*

Audio Ports and Game/MIDI Port Extension Bracket

This bracket provides three audio jacks for stereo line in, stereo line out and microphone. In addition it has a 15-pin D-connector which can be used by either a joystick or a MIDI device.

If you are using a four channel speaker system, channel one and two are output through the Stereo Line-out, and the rear speaker channels three and four are output through Stereo Line-in.

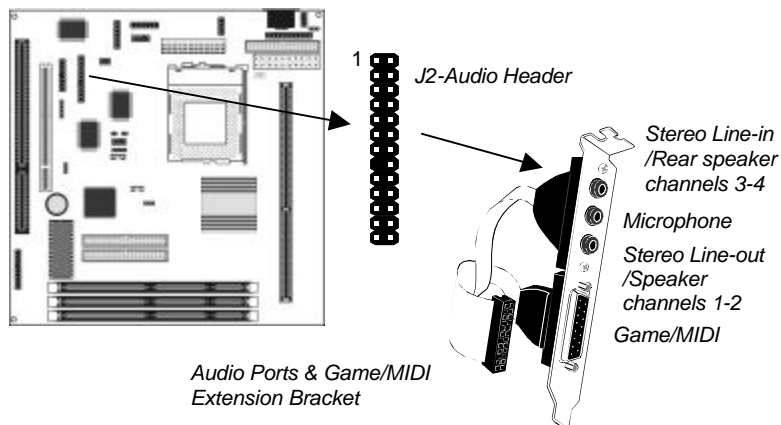

1. On the mainboard, locate the J2 audio header for this bracket.
2. Plug the cable from the bracket into the J2 audio header.
3. In the system chassis, remove a blanking plate from one of the expansion slots and install the extension bracket in the slot. Use the screw that held the blanking plate in place to secure the extension bracket.

Serial/Parallel Ports Extension Bracket

This bracket has one serial port - COM1 (9-pins) and one parallel port - LPT1 (25pins). On this mainboard, the second serial port is reserved for the fax/modem card so you can only connect one of the serial ports to the mainboard header COM1.

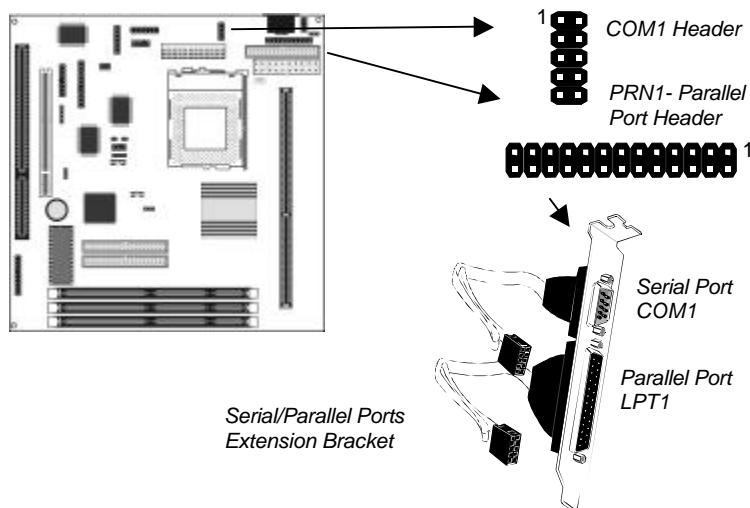

1. On the mainboard, locate the headers COM1 and PRN1 for this bracket.
2. Plug the serial cable into COM1 and the parallel cable into PRN1.
3. In the system chassis, remove a blanking plate from one of the expansion slots and install the extension bracket in the slot. Use the screw that held the blanking plate in place to secure the extension bracket.

LAN Adapter Extension Bracket

This bracket supports an RJ45 network connector and connects to the built in LAN1 header on the mainboard.

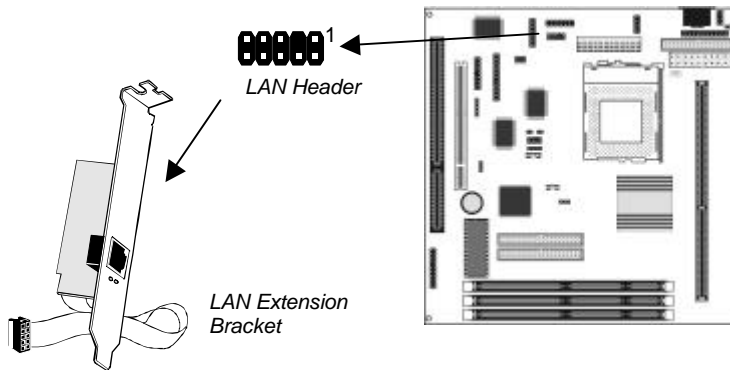

1. On the mainboard, locate the LAN1 header for this bracket.
2. Plug the cable from the bracket into the LAN header.
3. In the system chassis, remove a blanking plate from one of the expansion slots and install the extension bracket in the slot. Use the screw that held the blanking plate in place to secure the extension bracket.

Fax/modem DAA Module

The fax/modem DAA module plugs directly into the mainboard adjacent to an expansion slot in the system chassis. When you remove the blanking plate from the system chassis, you can access the LINE and TEL RJ11 connectors on the metal edge of the Fax/modem DAA module.

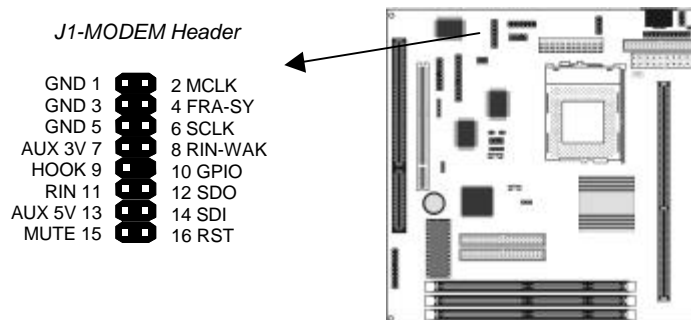

1. Locate the J1 modem header on the mainboard.
2. Plug the fax/modem DAA module into the J1 modem header.
3. Remove the blanking plate adjacent to the fax/modem DAA module.

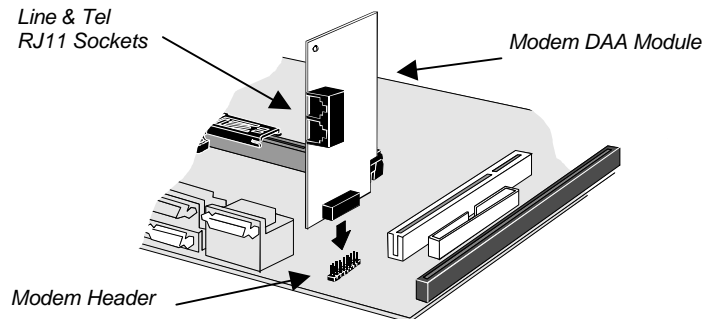

VGA Extension Card

The VGA extension card has a 15-pin connector for an external monitor cable.

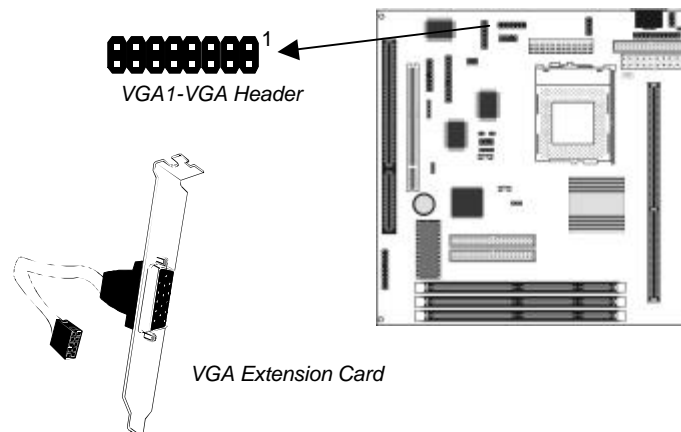

1. On the mainboard, locate the VGA1 header for this bracket.
2. Plug the cable from the bracket into the VGA1 header.
3. In the system chassis, remove a blanking plate from one of the expansion slots and install the extension bracket in the slot. Use the screw that held the blanking plate in place to secure the extension bracket.

Optional Extension Brackets

For this mainboard, you can also obtain an ATX Form Card and an SPDIF digital audio extension bracket. Install these brackets by following the steps below.

ATX Form Card

This ATX Form Card provides a mini-DIN PS/2 port for infrared, one mini-DIN port for a PS/2 mouse. In addition it has two USB (Universal Serial Bus) ports.

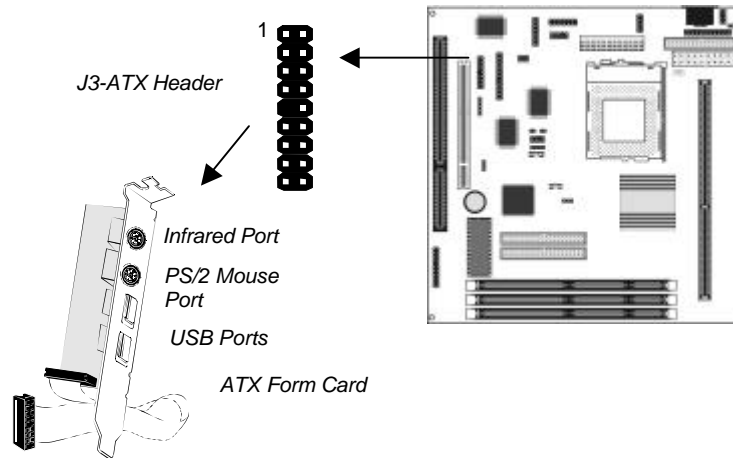

1. On the mainboard, locate the J3 ATX header for this bracket.
2. Plug the cable from the bracket into the J3 ATX header.
3. In the system chassis, remove a blanking plate from one of the expansion slots and install the extension bracket in the slot. Use the screw that held the blanking plate in place to secure the extension bracket.

Note: If you install an infrared port, it has to share resources with the fax/modem card. Therefore you cannot use the infrared port and the fax/modem card at the same time.

Digital Audio Extension Bracket

This bracket has two RCA jacks for digital audio in and digital audio out, and an auxiliary jack for a Stereo Line-in device.

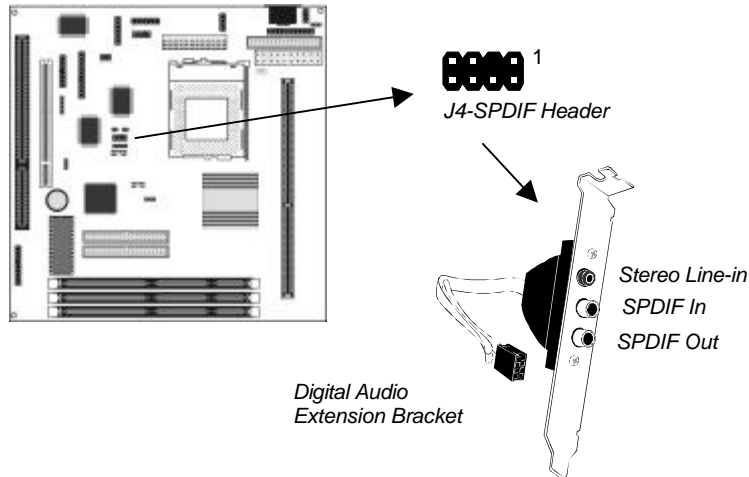

1. On the mainboard, locate the J4 SPDIF header for this bracket.
2. Plug the cable from the bracket into the J4 SPDIF header.
3. In the system chassis, remove a blanking plate from one of the expansion slots and install the extension bracket in the slot. Use the screw that held the blanking plate in place to secure the extension bracket.

Note: If you install the Digital Audio Extension Bracket, you cannot use the Internal SPDIF/In header (See Internal Sound Connections later in this chapter).

Install Other Devices

Install and connect any other devices in the system following the steps below.

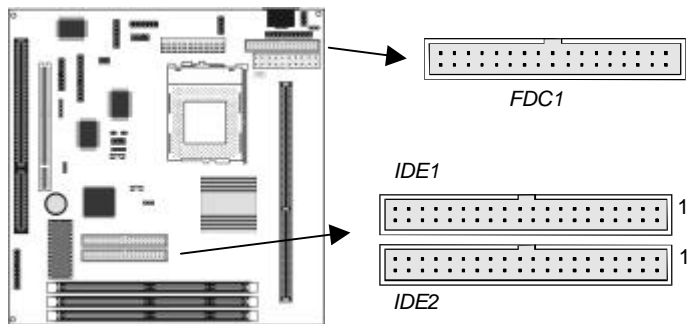

Floppy Disk Drive

The mainboard ships with a floppy disk drive cable that can support one or two drives. Drives can be 3.5" or 5.25" wide, with capacities of 360K, 720K, 1.2MB, 1.44MB, or 2.88MB.

Install your drives and supply power from the system power unit. Use the cable provided to connect the drives to the floppy disk drive header FDC1.

IDE Devices

IDE devices include hard disk drives, high-density diskette drives, and CD-ROM/DVD drives.

The mainboard ships with an IDE cable that can support one or two IDE devices. If you connect two devices to a single cable, you must configure one of the drives as Master and one of the drives as Slave. The documentation of the IDE device will tell you how to configure for Master or Slave.

Install the device(s) and supply power from the system power unit. Use the cable provided to connect the device(s) to the Primary IDE channel connector IDE1 on the mainboard.

If you want to install more IDE devices, you can purchase a second IDE cable and connect one or two devices to the Secondary IDE channel connector IDE2 on the mainboard. If you have two devices on the cable, one must be Master and one must be Slave.

Internal Sound Connections

If you have installed a CD-ROM drive or a DVD drive, you can connect the sound output of the drive to the built-in sound system.

On the mainboard, locate the two 4-pin connectors for CD1 and CD2. There are two kinds of connector because different brands of CD-ROM drive have different kinds of cable connectors on their audio output cable. Connect the cable to the appropriate connector.

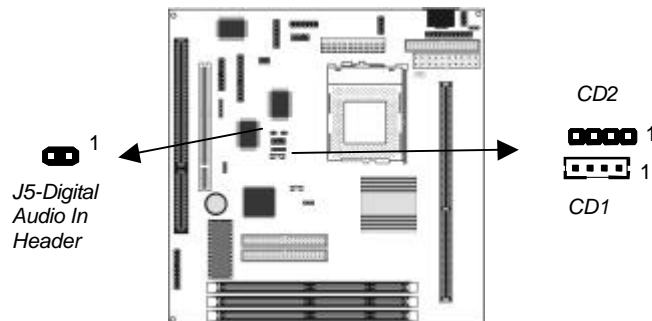

Digital Audio Connection

If your CD-ROM or DVD drive has 24-bit digital audio output, and your system is equipped to output sound through the SPDIF digital audio connector, you can use an optional internal digital audio cable to connect the digital output from the drive to the digital audio input connector on the mainboard.

Note: Do not use the Digital Audio In header, If you have already installed the optional Digital Audio Extension Bracket.

Expansion Slots

This mainboard has one 32-bit PCI expansion slot and one 8/16-bit ISA slot. The slots are shared. This means that you can only use one of the slots at one time.

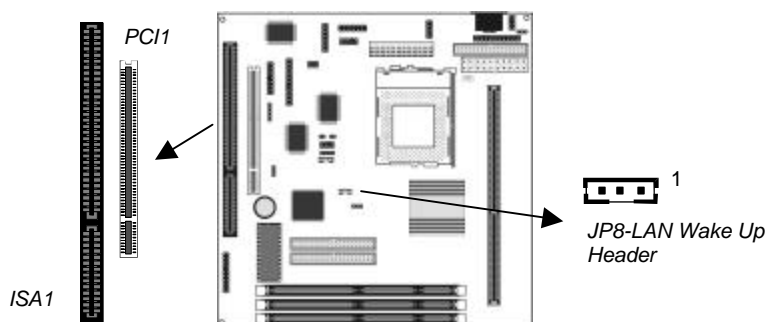

Follow the steps below to install a PCI or ISA expansion card.

1. Locate the ISA or PCI slot on the mainboard.
2. Remove the blanking plate from the appropriate expansion slot on the system chassis.
3. Install the edge connector of the expansion card into the slot and press it quite firmly down so that it is seated correctly.
4. Secure the bracket of the card into the expansion slot in the system chassis using the screw that held the blanking plate in place.

LAN Wake Up

If you are using an ATX power supply you can configure your system so that it powers down by software and can be resumed by alarms.

If you have installed a LAN adapter expansion card, connect the card to the LAN Wake Up header JP8. This allows incoming traffic to resume the system from a software power down.

Chapter 3

BIOS Setup

Introduction

The BIOS setup utility stores information about your computer such as the date and time, the kind of hardware you have installed, and so on. Your computer uses this information to initialize all the components at boot up time, and make sure that everything runs smoothly.

If the information in the setup utility is incorrect, it may cause your system to malfunction. It can even stop your computer from booting properly. If this happens, you can use the clear CMOS jumper to clear the CMOS memory area that is used to store the setup information, or you can hold down the **End** key while you reboot your computer. Holding down the **End** key also clears the setup information.

You can run the setup utility and manually make changes to the setup utility. You might need to do this to configure some of the hardware that you add to the mainboard, such as the CPU, the memory, disk drive, etc.

Running the Setup Utility

Each time your computer starts, before the operating system is booted, a message appears on the screen that prompts “Hit if you want to run SETUP”. When you see this message, press the **Delete** key and the Mainmenu page of the setup utility appears on your monitor.

AMIBIOS SIMPLE SETUP UTILITY - VERSION 1.20 (C)1998 American Megatrends, Inc. All Rights Reserved			
Standard CMOS Setup		Features Setup	
Advanced Setup		CPU PnP Setup	
Power Management Setup		Hardware Monitor	
PCI / Plug and Play Setup		Change Password	
Load Optimal Settings		Exit	
Load Best Performance Settings			
ESC: Quit	F1<->: Select Item	(Shift)F2: Change Color	F5: Old Values
F6: Optimal values	F7: Best performance values		F10: Save&Exit
Standard CMOS setup for changing time, date, hard disk type, etc.			

You can use the cursor arrow keys to highlight any of the options on the Mainmenu page. Press **Enter** to select the highlighted option. To leave the setup utility, press the **Escape** key. Hold down the **Shift** key and press **F2** to cycle through the optional color schemes of the setup utility.

Some of the options on the Mainmenu page lead to tables of items with installed values. In these pages, use the cursor arrow keys to highlight the items, and then use the **PgUp** and **PgDn** keys to cycle through the alternate values for each of the items. Other options on the Mainmenu page lead to dialog boxes which require you to answer Yes or No by hitting the **Y** or **N** keys.

If you have already made changes to the setup utility, press **F10** to save those changes and exit the utility. Press **F5** to reset the changes to the original values. Press **F6** to install the setup utility

with a set of default values. Press **F7** to install the setup utility with a set of high-performance values.

Standard CMOS Setup Page

Use this page to set basic information such as the date and time, the IDE devices, and the diskette drives. If you press the F3 key, the system will automatically detect and configure the hard disks on the IDE channels.

AMIBIOS SETUP - STANDARD CMOS SETUP										
(C)1998 American Megatrends, Inc. All Rights Reserved										
Date (mm/dd/yyyy): Mon Apr 12, 1999										
Time (hh/mm/ss) : 12:00:44										
	Type	Size	Cyln	Head	WPcom	Sec	Mode	Mode	Mode	LBA B1k PIO 32Bit
Pri Master	: Not Installed									
Pri Slave	: Not Installed									
Sec Master	: Not Installed									
Sec Slave	: Not Installed									
Floppy Drive A: Not Installed										
Floppy Drive B: Not Installed										
Month: Jan - Dec					ESC : Exit					
Day: 01 - 31					↑↓ : Select Item					
Year: 1901 - 2099					PU/PD/+/- : Modify					
					(Shift)F2 : Color					
					F3 : Detect All HDD					

Date & Time	Use these items to install your system with the correct date and time
Pri Master Pri Slave Sec Master Sec Slave	Use these items to configure devices on the primary and secondary IDE channels. To configure a hard disk drive, choose <i>Auto</i> . If the <i>Auto</i> setting fails to find a hard disk drive, set it to <i>User</i> , and then fill in the hard disk characteristics (Size, Cyls, etc.) manually. If you have a CD-ROM drive, select the setting <i>CDROM</i> . If you have an ATAPI device with removable media (e.g. a ZIP drive or an LS-120) select <i>ARMD</i> .
Floppy Drive A Floppy Drive B	Use these items to set the size and capacity of the floppy diskette drive(s) installed in the system.

Advanced Setup Page

Use this page to set more advanced information about your system. Take some care with this page. Making changes can affect the operation of your computer.

AMIBIOS SETUP - ADVANCED SETUP	
(C)1998 American Megatrends, Inc. All Rights Reserved	
Share Memory Size	Disabled
Trend ChipAwayVirus	Enabled
1st Boot Device	IDE-0
2nd Boot Device	Floppy
Try Other Boot Devices	Yes
S.M.A.R.T. for Hard Disks	Disabled
BootUp Num-Lock	On
Floppy Drive Swap	Disabled
Floppy Drive Seek	Disabled
Password Check	Setup
Boot To OS/2 Over 64MB	No
Internal Cache	Reserved
System BIOS Cacheable	Disabled
SDRAM Speed	8ns
Refresh Queue Depth	4
SDRAM CAS Latency	3T
Graphic Win Size	64M
ESC : Quit ↑↓↔ : Select Item F1 : Help PU/PD/+/- : Modify F5 : Old Values (Shift)F2 : Color F6 : Load BIOS Defaults F7 : Load Setup Defaults	

Share Memory Size	This item lets you allocate a portion of the main memory for use by the onboard VGA system.
Trend ChipAway Virus	This mainboard has built-in virus protection in the firmware. Use this item to enable or disable the built-in virus protection.
1st Boot Device 2nd Boot Device	Use these two items to determine the order and priority that your computer follows to load an operating system at start-up time.
Try Other Boot Device	If you enable this item, the system will also search for other boot devices if it fails to find an operating system from the first two locations.
S.M.A.R.T. for Hard Disks	Enable this item if your hard disk(s) supports SMART (Self-Monitoring, Analysis and Reporting Technology).
BootUp Num-Lock	This items determines if the Num Lock key is active or inactive at system start-up time.
Floppy Drive Swap	If you have two diskette drives installed and you enable this item, drive A becomes drive B and drive B becomes drive A.

Floppy Drive Seek	If you enable this item, your system will check the diskette drives at start up time. Disable this item unless you are using an old 360K diskette drive.
Password Check	If you have installed a password on your system, use this item to determine if the password is required to enter the setup utility (<i>Setup</i>) or required at start-up time and to enter the setup utility (<i>Always</i>).
Boot to OS/2 Over 64MB	Enable this item if you are booting the OS/2 operating system and you have more than 64MB of memory installed.
Internal Cache	Leave this item enabled since all the processors that can be installed on this board have internal cache memory.
System BIOS Cacheable	If you enable this item, a segment of the system BIOS will be cached to main memory for faster execution.
SDRAM Speed	This item determines the speed of the installed SDRAM main memory. We recommend that you leave this item at the default value.
Refresh Queue Depth	This item determines the operation of the memory refresh timing. We recommend that you leave this item at the default value.
SDRAM CAS Latency	This item determines the operation of the main memory CAS (column address strobe). We recommend that you leave this item at the default value.
Graphic Win Size	This item determines the operation of the onboard graphics adapter. We recommend that you leave this item at the default value.

Power Management Setup Page

This page sets some of the parameters for the system power management operation.

AMIBIOS SETUP - POWER MANAGEMENT SETUP	
(C)1998 American Megatrends, Inc. All Rights Reserved	
Power Management/APM	Disabled
Standby Time Out (Minute)	Disabled
Suspend Time Out (Minute)	Disabled
Keyboard Power On	Disabled
Lan Card Power On	Disabled
Ring On Power On	Disabled
RTC Alarm Power On	Disabled
RTC Alarm Date	15
RTC Alarm Hour	12
RTC Alarm Minute	30
RTC Alarm Second	30
ESC : Quit ↑↓←→ : Select Item F1 : Help PU/PD/+/- : Modify F5 : Old Values (Shift) F2 : Color F6 : Load BIOS Defaults F7 : Load Setup Defaults	

Power Management/APM	Use this item to enable or disable the power management routines. If you enable the power management, you can use the items below to set the power management operation.
Standby Time Out (Minute)	This sets the timeout for standby mode in minutes. If the time selected passes without any system activity, the computer will enter the power-saving standby mode.
Suspend Time Out (Minute)	This sets the timeout for suspend mode in minutes. If the time selected passes without any system activity, the computer will enter the power-saving suspend mode.
Keyboard Power On	Your system can enter a software power down. If you enable this item, you can resume the system by pressing hot keys on the keyboard. You must be using an ATX power supply and enable jumper JP1 in order to use this feature.

Lan Card Power On	Your system can enter a software power down. If you enable this item, the system can automatically resume if there is traffic on the built-in network adapter. You must have an ATX power supply in order to use this feature.
Ring On Power On	Your system can enter a software power down. If you enable this item, the system can automatically resume if there is an incoming call on the built-in fax/modem. You must have an ATX power supply in order to use this feature.
RTC Alarm Power On	Your system can enter a software power down. If you enable this item, the system can automatically resume at a fixed time on the system's RTC (realtime clock). Use the items below to set the date and time of the wake-up alarm. You must have an ATX power supply in order to use this feature.

PCI / Plug and Play Setup Page

This page sets some of the parameters for devices installed on the system PCI bus, and devices that use the system plug and play capability.

AMIBIOS SETUP - PCI / PLUG AND PLAY SETUP (C)1998 American Megatrends, Inc. All Rights Reserved	
Plug and Play Aware O/S	Yes
Primary Graphics Adapter	PCI
PCI UGA Palette Snoop	Disabled
Allocate IRQ to UGA	No
DMA Reserved for ISA	N/A
IRQ Reserved for ISA	N/A
Reserved Memory Size	Disabled
Reserved Memory Address	C8000
ESC : Quit ↑↓↔ : Select Item F1 : Help PU/PD/+/- : Modify F5 : Old Values (Shift) F2 : Color F6 : Load BIOS Defaults F7 : Load Setup Defaults	

Plug and Play Aware O/S	Enable this item if you are using an O/S that supports Plug and Play such as Windows 95 or
-------------------------	--

98.

Primary Graphics Adapter	Use this item to define if your primary graphics adapter is installed in a PCI slot or on an AGP bus.
PCI VGA Palette Snoop	When this item is enabled, multiple VGA devices operating on different buses can handle data from the CPU on each set of palette registers on every video device.
Allocate IRQ to PCI VGA	If this item is enabled, an IRQ will be assigned to the PCI VGA graphics system. We recommend that you set this value to No.
DMA Reserved for ISA	If you set it to a DMA, the channel will be reserved for an installed non-PnP ISA or EISA expansion card.
IRQ Reserved for ISA	If you set it to an IRQ, the IRQ line will be reserved for an installed non-PnP ISA or EISA expansion card.
Reserved Memory Size	This item lets you reserve a block of memory for any device that requires it.
Reserved Memory Address	This item lets you set the address for any block of memory that has been reserved.

Load Optimal Settings

If you select this item and press **Enter** a dialog box appears. If you press **Y**, and then **Enter**, the setup utility is loaded with a set of optimal default values. The optimal default values are not very demanding and they should allow your system to function with most kinds of hardware and memory chips.

Load Best Performance Settings

If you select this item and press **Enter** a dialog box appears. If you press **Y**, and then **Enter**, the setup utility is loaded with a set of best-performance default values. The optimal default values are quite demanding and your system might not function properly if you are using slower memory chips or other kinds of low-performance components.

Features Setup Page

This page sets some of the parameters for peripheral devices installed on the system.

AMIBIOS SETUP - FEATURES SETUP	
(C)1998 American Megatrends, Inc. All Rights Reserved	
OnBoard FDC	Enabled
OnBoard Serial Port1	3F8h/COM1
OnBoard IR Port	Disabled
IR Duplex	Half
OnBoard Parallel Port	378h
Parallel Port Mode	Normal
Parallel Port IRQ	?
Parallel Port DMA	N/A
Onboard PCI IDE	Both
Ultra DMA Support	Disabled
USB Function	Disabled
USB Function for DOS	Disabled
ESC : Quit ↑↓↔ : Select Item F1 : Help PU/PD/+/- : Modify F5 : Old Values (Shift) F2 : Color F6 : Load BIOS Defaults F7 : Load Setup Defaults	

Onboard FDC	Use this item to enable or disable the onboard floppy disk drive interface.
Onboard Serial Port1	Use this item to enable or disable the onboard serial port COM1, and to assign a port address
Onboard IR Port	Use this item to define the protocol for an infrared port if you have installed an optional IR port.
IR Duplex	Use this item to define if the optional infrared port is full-duplex or half-duplex.
Onboard Parallel Port	Use this item to enable or disable the onboard parallel port LPT1, and to assign a port address
Parallel Port Mode	Use this item to determine the parallel port mode. You can select Normal, ECP (Extended Capabilities Port), EPP (Enhanced Parallel Port), or ECP + EPP.
Parallel Port IRQ	Use this item to assign an IRQ to the parallel port.
Parallel Port DMA	Use this item to assign a DMA channel to the parallel port.

Onboard IDE	Use this item to enable or disable either of the two onboard IDE channels, Primary or Secondary.
Ultra DMA Support	Use this item to determine if you require Ultra DMA support for IDE devices on the primary or secondary IDE channels.
USB Function	Enable this item if you plan to use the USB ports that are integrated on this mainboard.
USB Function for DOS	Enable this item if you plan to use the USB ports that are integrated on this mainboard in the DOS environment.

CPU PnP Setup Page

This page lets you manually configure the mainboard for the CPU. The system will automatically detect the kind of CPU that you have installed and make the appropriate adjustments to the items on this page.

AMIBIOS SETUP - CPU PnP SETUP (C)1998 American Megatrends, Inc. All Rights Reserved	
CPU Speed	233MHZ
CPU Base Frequency	66MHZ
CPU Multiple Factory	X3.5
SDRAM Frequency	66MHZ
ESC : Quit ↑↓←→ : Select Item F1 : Help PU/PD/+/- : Modify F5 : Old Values (Shift)F2 : Color F6 : Load BIOS Defaults F7 : Load Setup Defaults	

CPU Speed	Use this item to set the internal clock speed of your CPU.
CPU Base Frequency	Use this item to set the system bus frequency that is required by the CPU.

CPU Multiple Factory	Use this item to set a multiplier for the system bus frequency. The multiplier x the system bus frequency must equal the internal clock speed of your CPU, e.g. 100 MHz (system bus) x 3.5 (multiplier) = 350 MHz (internal clock speed of installed CPU).
-------------------------	--

SDRAM Frequency	Use this item to set the bus frequency for the memory bus.
-----------------	--

Hardware Monitor Page

This page sets some of the parameters for the hardware monitoring function of this mainboard.

AMIBIOS SETUP - HARDWARE MONITOR (C)1998 American Megatrends, Inc. All Rights Reserved	
System Hardware Monitor	
CPU Temperature	41°C/125°F
CPU FAN Speed	
Vcc 5.0V	5.000 V
Vcc 3.3V	3.300 V
Vcc 2.5V	2.500 V
Vcore	2.000 V
ESC : Quit F4+ : Select Item F1 : Help PU/PD+/- : Modify F5 : Old Values (Shift) F2 : Color F6 : Load BIOS Defaults F7 : Load Setup Defaults	

CPU Temperature	Use this item to set the threshold temperature for the CPU. The system will alert you if this temperature is exceeded.
-----------------	--

CPU FAN Speed & Vcore	Use these items to set the parameters for the voltages that control the fans and the CPU core. If the values deviate by an amount greater than the values installed here, the hardware monitoring will alert you with a warning .
--------------------------	---

Change Password

If you highlight this item and press **Enter**, a dialog box appears which lets you enter a Supervisor password. You can enter no more than six letters or numbers. Press **Enter** after you have typed in the password. A second dialog box asks you to retype the password for confirmation. Press **Enter** after you have retyped it correctly. The password is required at boot time, or when the user enters the setup utility.

Change or Remove the Password

Highlight this item and type in the current password. At the next dialog box, type in the new password, or just press Enter to disable password protection.

Exit

Highlight this item and press **Enter** to save the changes that you have made in the setup utility and exit the setup program. When the Save and Exit dialog box appears, press **Y** to save and exit, or press **N** to exit without saving.

Chapter 4

Software & Applications

Introduction

The support software CD-ROM that is included in the mainboard package contains all the drivers and utility programs needed to properly run our products. Below you can find a brief description of each software program, and the right location for your mainboard version. More information on each individual program might be available in a README file, located in the same directory as the software.

In order to run the software, put the support software CD-ROM in the CD-ROM drive, and execute the EXE file name given in the description below.

***Note:** The correct path name for each software driver is provided, where **D:** identifies the CD-ROM drive letter – modify if necessary.*

Bus Master IDE Driver

The IDE Bus Master Drivers allows the system to properly manage the IDE channels on the mainboard. You only need to install an IDE driver if you are running Windows 95.

- ◆ Windows 95 – D:\IDE\M748LMRT\WIN9x\SETUP.EXE

USB Driver

The USB Driver allows the system to recognize the USB ports on the mainboard. You need to install this driver if you are running Windows 95.

This driver is available for:

- ◆ Windows 95 – D:\USB\EUSBSUPP\USBSUPP.EXE
- ◆ Windows 95 (Chinese) –
D:\USB\CUSBSUPP\CUSBSUPP.EXE

Sound Driver

The Sound driver allows the system to generate optimal sound effects.

This driver is available for:

- ◆ DOS & Windows 3.x – D:\SOUND\Driver\8738AM\DOS-W31\
- ◆ Windows 95/98 – D:\SOUND\Driver\8738AM\W95-98\
- ◆ Windows NT – D:\SOUND\Driver\8738AM\Nt40DRV\

There is also an Audio Rack application program available for:

- ◆ Windows 95/98 - D:\SOUND\Gamut\Gamut98

Graphics Drivers and Software

Find the Graphics drivers and software here:

- ◆ D:\VGA\M748LMRT\Win9x\SETUP.EXE

Fax/Modem Drivers and Software

Find the fax/modem drivers and software here:

- ◆ D:\Modem\8738\Win9x
- ◆ D:\Modem\SuperVoice\

Network Adapter Driver

Find the network adapter driver here:

- ◆ D:\LAN\Davicom9102

BIOS Update Utility

The BIOS Update utility allows you to update the BIOS setup file on your mainboard to a newer version. You can download the latest version of the BIOS setup available for your mainboard from the website.

- ◆ D:\UTILITY\AMIFL815.EXE

PC-Cillin Software

The PC-Cillin software program provides anti-virus protection for your system.

This program is available for:

- ◆ DOS – D:\PC-CILLIN\DOS\PCSCAN.EXE

- ◆ Windows 95 – D:\PC-CILLIN\WIN95\DISK1\SETUP.EXE
- ◆ Windows 98 – D:\PC-CILLIN\WIN98\SETUP.EXE

ADCM Software

The AMI Desk-Client Management software provides network management services.

This software is available for:

Windows 95/98 – D:\AMI ADCM\WIN95&98\SETUP.EXE

Media Ring Talk Software

- ◆ D:\Modem\MediaRingTalk\

Using the PCI Sound Application

1. Before you install the PCI Sound drivers, make sure your Operating System has been installed, otherwise the PCI Sound might be detected as “Other device” by the device manager of your OS.
2. After the drivers are properly installed, choose the MULTIMEDIA icon in the CONTROL PANEL when you need to use the Software Wave-Table drivers as a MIDI output device. Select the MIDI page and click on “C-media SoftMidi Synthesis (Win98) / Driver (Win95)”, then click “OK” to confirm.
3. A Windows application named Audio Rack is provided with the PCI Sound drivers, which gives you control over all the audio functions through a user interface that is as simple to use as a home stereo system. We recommend that you use the System Mixer in the Audio Rack software to control your computer’s audio volume, recording device and the recording gain.
4. If the devices that you are using require the MIDI port as the control interface, you need to select the MULTIMEDIA icon in the CONTROL PANEL. Select the MIDI page and click on “CM8738 MPU-401” (Win98) or “CM8738/C3DX PCI Audio External MIDI Port” (Win95), and then click “OK” to confirm.
5. For more information, refer to the PCI Sound manual in the CD which ships with this mainboard.

The Four Speakers System

The onboard Sound Pro audio system supports 2 wave channels (front/rear) known as the 4 speaker system. If you are running applications which use the DirectSound® 3D or A3D® audio interface, your system can simulate realistic 3D sound through a 4 speaker setup. Follow the steps below to install a 4-speaker setup.

Speaker Installation

Connect the front two speakers to the Line-out jack on the sound ports extension bracket. Connect the rear two speakers to the Line-in/Rear jack on the sound ports extension bracket. The original Line-in can be moved to Aux.

Speaker Position

Set up your speakers similar to the following figure to get the best audio result.

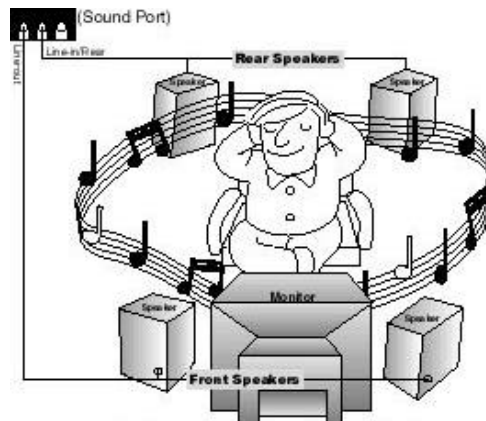

A picture on the 4 speakers application.

Mixer Setup

There is a 4-speakers option in the Volume Control of the Mixer when you are setting up the PCI Audio Application. Click on the 4 SPK icon to enable this option. This means that the output to the rear speakers is sent through the Line-in/Rear jack. In order to avoid hardware conflicts, **DO NOT** enable this option when the Line-in/Rear jack is connected with a line-in device. While the 4

speakers mode is enabled, turn on/off the output of the front speakers and adjust the volume of the speakers so that the front/rear speakers have the same volume.

Demo

Execute the “Helicopter” demo in the C3D HRTF Positional Audio Demos of the PCI Audio Application. When you hear the helicopter flying behind you, it means that the rear speakers are working properly.